

# *Undercounter Series*



## TABLE OF CONTENTS

## WARRANTY

### Sub-Zero Undercounter Features

- Models 245, 249R & 249RP .....3
- Models 249FF .....4

### Product Operation

- Temperature Controls
  - A. Adjustment .....5
  - B. Location .....5
- Door Closing .....5
- Fan Operation .....5
- Automatic Defrost Into .....5
- Sounds .....5
- Icemaker Operation .....6

### Product Care

- Maintenance & Cleaning .....6
- Light Bulb Replacement .....6
- Vacation Time .....6
- Vacant Homes .....6

### Food Storage Suggestions .....7

### Product Loading Information .....7

### Service Information .....7

## RECORD YOUR MODEL AND SERIAL NUMBER

On undercounter models 245, 249R, 249RP and 249FF, the serial number is found on the inside cabinet liner at the top; open the door to read.

Have this information ready when calling for service:

Model Number

Serial Number

Installation Date

Factory Authorized Service Agent  
(Phone Number)

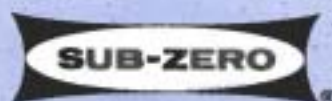

## “PROTECTION PLAN”

**Full 5 Year Warranty and Limited 6th Through  
12th Year Warranty on the Sealed System  
Full 2 Year Warranty on the Total Product**

### FULL FIVE YEAR WARRANTY

For five years from the date of original installation, your Sub-Zero warranty covers all parts and labor to repair or replace any components that prove to be defective in materials or workmanship in the sealed system. The sealed system consists of the compressor, condenser, evaporator, drier and all connecting tubing.

### FULL TWO YEAR WARRANTY

For two years from the date of original installation, your Sub-Zero warranty covers all parts and labor to repair or replace any part of the product which proves to be defective in materials or workmanship.

### LIMITED 6TH THROUGH 12TH YEAR WARRANTY

From the 6th through the 12th year from the date of original installation, your Sub-Zero warranty covers all parts that prove to be defective in materials or workmanship in the sealed system (parts only). The sealed system consists of the compressor, condenser, evaporator, drier and all connecting tubing.

### TERMS APPLICABLE TO EACH WARRANTY

All service provided by Sub-Zero under the above warranty must be performed by authorized Sub-Zero service representatives, unless otherwise specified by Sub-Zero. Service will be provided in the home during the normal business hours. This warranty applies only to products installed for normal residential use. A separate nonresidential warranty is available upon request.

The warranty applies only to products installed in any one of the fifty states of the United States, the District of Columbia or the ten provinces of Canada. This warranty does not cover any parts or labor to correct any defect caused by negligence, accident or improper use, maintenance, installation, service or repair, including but not limited to improper removal and reinstallation (whether in the unit or at a remote location) of the condensing unit.

**THE REMEDIES DESCRIBED ABOVE FOR EACH WARRANTY ARE THE ONLY ONES WHICH SUB-ZERO WILL PROVIDE, EITHER UNDER THESE WARRANTIES OR UNDER ANY WARRANTY ARISING BY OPERATION OF LAW. SUB-ZERO WILL NOT BE RESPONSIBLE FOR ANY CONSEQUENTIAL OR INCIDENTAL DAMAGES ARISING FROM THE BREACH OF THESE WARRANTIES OR ANY OTHER WARRANTIES, WHETHER EXPRESS, IMPLIED OR STATUTORY.**

Some states do not allow the exclusion or limitation of incidental or consequential damages, so the above limitation or exclusion may not apply to you. This warranty gives you specific legal rights and you may also have other legal rights which vary from state to state.

To receive parts and/or service and the name of the Sub-Zero authorized service representative nearest you, contact your Sub-Zero dealer or distributor or contact Sub-Zero Freezer Company, Service Department, P.O. Box 44130, Madison, Wisconsin 53744-4130 or call: (800) 222-7820 or e-mail us at [customerservice@subzero.com](mailto:customerservice@subzero.com).

## UNDERCOUNTER MODELS

### MODEL 245

- 1) Automatic icemaker
- 2) Adjustable Freezer Control
- 3) Adjustable Refrigerator Control
- 4) Interior Freezer Light
- 5) Automatic Defrost Blower Assembly
- 6) One-piece Interior
- 7) Main Shelf (**Not Removable**)
- 8) Upper Refrigerator Shelf
- 9) Four-sided Magnetic Gasket
- 10) Door Hinge (can be changed from right to left).\*
- 11) Serial and Model Number Location
- 12) Ventilated Toe Kickplate Area
- 13) Door Closer
- 14) Door Shelves
- 15) Front Venting
- 16) Interior Refrigerator Light

\* No kit necessary. Use existing hardware.

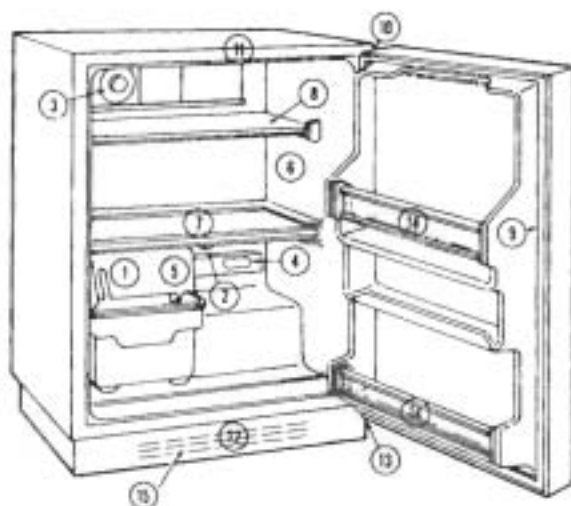

### MODEL 249R REFRIGERATOR (MANUAL DEFROST)

- 1) Freezer Section (has two ice cube trays)
- 2) Adjustable Shelves
- 3) Door Storage Shelves
- 4) Adjustable Temperature Control
- 5) Interior Light
- 6) One-piece Interior
- 7) Four-sided Magnetic Gasket
- 8) Door Hinge \*
- 9) Serial and Model Number Location
- 10) Ventilated Toe Kickplate Area
- 11) Front Venting
- 12) Door Closer

\* Accessory door swing change kits available from your distributor.

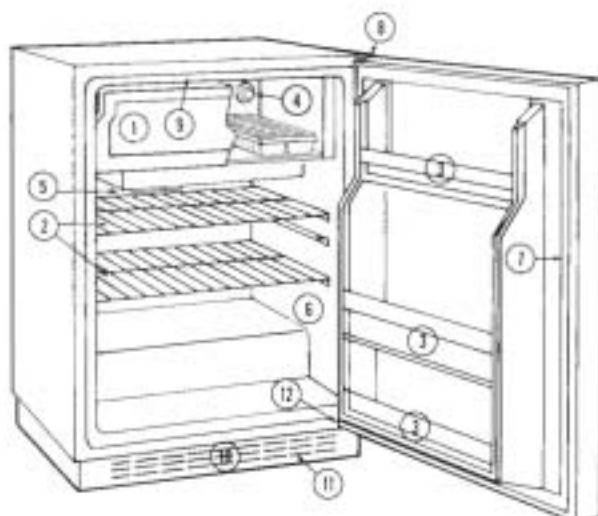

### 249RP REFRIGERATOR

- 1) Cooling Plate
- 2) Adjustable Shelves
- 3) Door Storage Shelves
- 4) Adjustable Temperature Control
- 5) Interior Light
- 6) One-piece Interior
- 7) Four-sided Magnetic Gasket
- 8) Door Hinge \*
- 9) Serial and Model Number Location
- 10) Ventilated Toe Kickplate Area
- 11) Front Venting
- 12) Door Closer

\* Accessory door swing change kits available from your distributor.

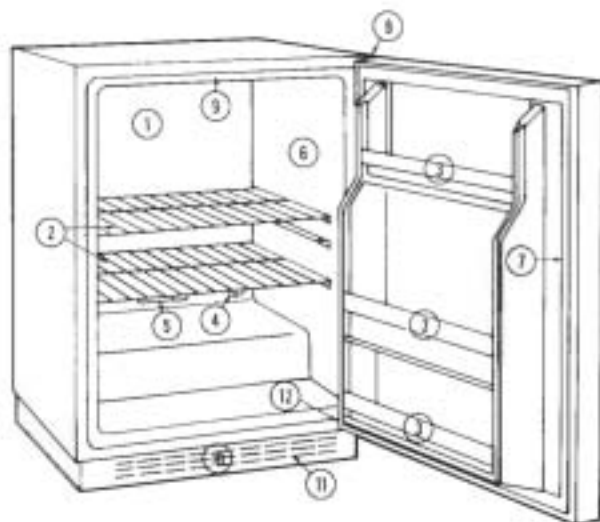

## UNDERCOUNTER MODELS

### 249FF FREEZER



- 1) Adjustable Shelves
- 2) Adjustable Temperature Control
- 3) Interior Light
- 4) Automatic Defrost Blower Assembly
- 5) One-piece Interior
- 6) Four-sided Magnetic Gasket
- 7) Door Hinge \*
- 8) Serial and Model Number Location
- 9) Ventilated Toe Kickplate Area
- 10) Front Venting
- 11) Door Closer

\* Accessory door swing change kits available from your distributor.

Automatic icemaker available as an option but must installed at the factory.

## PRODUCT OPERATION

*The importance of the installation of your Sub-Zero CANNOT be overemphasized. The proper installation of your unit is the responsibility of the selling dealer or installer. Any questions or problems pertaining to the installation should be directed to the selling dealer*

### TEMPERATURE CONTROL LOCATION AND ADJUSTMENTS

Your new refrigerator and/or freezer was thoroughly inspected and tested before it was shipped from the Sub-Zero factory. During these procedures, the temperatures were preset to maintain approximately 38 degrees in the refrigerator section and approximately 0 degrees in the freezer section (except 249R). If you wish to make temperature adjustments, simply turn the temperature control dial. The higher the number the colder the temperature (#1 is the warmest and #7 is the coldest setting). For the location of the control, refer to the model of your Sub-Zero on the following pages.

You should be aware it is normal for the above temperatures to fluctuate slightly, depending on external influence such as: open door for extended periods, the degree of humidity present and room temperature.

#### A) ADJUSTMENT

To adjust the freezer and refrigerator controls on our models 245, 249R, 249RP and 249FF simply turn the control knob so the indicator lines up with the desired number.

#### B) LOCATION

##### MODEL 245

The freezer control is located on the back wall above and right of the icemaker assembly. (See Model 245 Features on page 3.) The refrigerator control is situated left of center at the top of the refrigerator compartment. (See Model 245 Features on page 3.)

##### MODEL 249R

##### (MANUAL DEFROST)

The control is situated on the right hand side of the back wall in the upper freezer compartment. (See Model 249RP Features on page 3.)

##### MODEL 249RP

The control is located on the right side of the back wall just below the lower shelf assembly. (See Model 249RP Features on page 3.)

##### MODEL 249FF

The control is found at the top of the freezer on the right side of the defrost blower assembly. (See Model 249FF Features on page 4.)

### DOOR CLOSING

#### MODEL 245

The doors on our model 245 are equipped with a door closing cam system to assist in the closing of the door. As you close the door, the cam will take over at approximately the 15 degree position to assist in the closing of the door.

#### MODELS 249R, 249RP AND 249FF

The refrigerator and freezer doors are both equipped with a spring-loaded door closure mechanism. As the doors are closed, the door closure engages at approximately the 15 degree position to assist the door in closing and sealing.

### CONDENSER FAN OPERATION

All undercounter units have one fan located behind the kickplate at the base of the unit. On all undercounter models the fan operates only **only** when the compressor is running.

### EVAPORATOR FAN OPERATION

#### MODELS 245 and 249FF

A fan motor is located in the freezer section on the models listed above. These fans operate **only** when the compressor is running.

### AUTOMATIC DEFROST INFORMATION

For your convenience, Sub-Zero has equipped the following models with an automatic defrost system: 245, 249RP and 249FF. **NOTE:** Our model 249R is **not** equipped with automatic defrost. To manually defrost, turn the a control knob to the off position.

### SOUNDS

Certain noises may be evident with the normal operation of the unit. Surrounding acoustics like walls, floors and cabinets may affect the sound level of your unit.

A gurgling sound or running water sound may be evident as the refrigerant circulates through the tubing.

During the icemaker cycle, you may hear the sound of ice dropping into the bucket or the solenoid valve while refilling the icemaker with water.

During the freezer defrost, you may hear crackling and/or sizzling as the heat from the defrost element clears the frost from the freezer coil and water runs into the defrost water pan.

While the compressors are in operation, a slight hum might be evident. During the startup and shutdown of the compressor, some vibration may occur lasting only a few seconds.

### ICEMAKER OPERATION

The icemaker in your Sub-Zero is fully automatic and has been factory pretested. To put into operation, it requires only a connection to the house water supply.

## PRODUCT CARE

### ICE PRODUCTION

The level of ice in the ice container is controlled by an ice level arm. When the containers are filled with ice, the ice level arm senses the level and shuts down the icemaker. As ice is used, the level drops and the level arm signals the icemaker to restore ice production.

These icemakers are designed to produce a more than adequate supply of ice for normal family consumption, the length of time between ice harvest cycles will vary depending on load conditions, door openings and ambient room temperatures. On the average, you can expect a harvest of ice every two hours.

If ice is not used regularly, it will tend to fuse together. To avoid this, empty the ice container periodically.

**NOTE:** To shut off icemaker, lift up icemaker stop arm to the up or off position (see Figure 1 below).

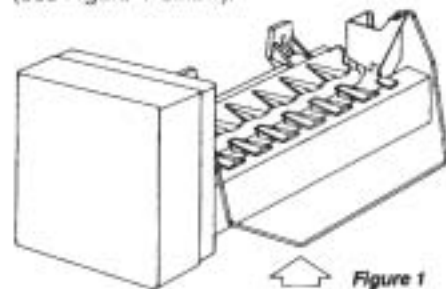

Figure 1

### MAINTENANCE AND CLEANING

#### CAUTION

**We recommend for maintenance and cleaning, that the circuit breaker to the refrigerator be shut off and protective gloves be worn.**

For general cleaning of the refrigerator and freezer interior surfaces and removable parts, wash with a mild solution of soap and water to which a small amount of baking soda has been added. Rinse and dry thoroughly. Avoid getting water on lights and/or control dial.

To insure proper performance, the cleaning of your unit's condenser is required.

**IMPORTANT!! This should be performed every 3 to 6 months under normal use and living conditions.**

To expose the condenser, remove the kickplate at the base of the unit. To do this simply remove the screws located at each corner of the kickplate.

Once the condenser is exposed, use a "soft" bristle brush and vacuum hose to remove the accumulation of dust and lint particles on the condenser (see Figure 2 below).

**IMPORTANT!! Failure to properly clean this area could result in temperature lost and/or possible mechanical failure of the refrigerator and/or freezer.**

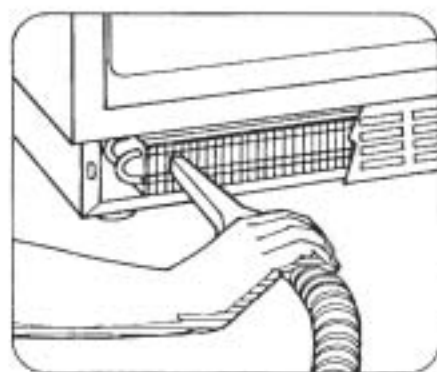

Figure 2

### LIGHT BULB REPLACEMENT

#### WARNING

**For your safety, the circuit breaker to the refrigerator should be shut off before replacing bulbs. Protective gloves should be worn when handling light bulbs.**

#### MODEL 245

To replace the refrigerator light bulb (25 watt), remove upper shelf and pull control knob off. Grip refrigerator control diffuser firmly on top and bottom and snap out of position. The light bulb is now accessible.

To replace the freezer light bulb (25 watt), pull control knob off. Grip freezer control diffuser firmly on top and bottom and snap out of position. The bulb is now accessible.

**To reinstall, reverse procedure.**

#### MODEL 249R

The light bulb (25 watt) is located beneath the freezer evaporator and is accessed by reaching up underneath behind the right hand side of the freezer section. Unscrew and replace.

## FOOD STORAGE SUGGESTIONS

#### MODEL 249RP

The light bulb (25 watt) is accessible by removing three screws which anchor the light bracket. Remove bracket and reach behind the light diffuser and unscrew bulb.

**To reinstall, reverse procedure.**

#### MODEL 249FF

The light bulb (25 watt) is mounted behind the left side of the blower fan assembly at the top of the back wall of the freezer.

Unscrew and replace.

### VACATION TIME

**For short vacations:** Remove all perishable items. Shut off the icemaker (see Icemaker Operation on page 5). Do **not** change the settings of your controls.

**For extended vacations:** The control(s) to your refrigerator or freezer should be shut off. Empty all contents in the refrigerator/freezer and wash, rinse and dry interior of unit.

**Vacant homes:** If for any reason this unit is put into service on a temporary basis and later shut off, the control(s) to the refrigerator or freezer should be shut off.

For extended vacations or vacant homes, you should block door(s) open slightly. About one inch, so fresh air can circulate and keep interior dry. You should also turn off power to the unit or loosen light bulb(s).

#### CAUTION

**The moisture developed during even the shortest amount of running time could attack the metal parts if the doors are left closed after shutting down. Be sure the doors are blocked open after any operation.**

## SERVICE INFORMATION

### FOOD STORAGE SUGGESTIONS

*New techniques are constantly being developed. Consult the College or County Extension Service or your local Utility Company for the latest information on freezing and storing food. \*U.S. Department of Agriculture*

#### **Fresh Food Storage**

Shelf life of fresh foods may vary, depending on the freshness at time of purchase. To keep your foods fresher longer, follow the recommended storage procedures.

#### **Vegetables**

Wash in cool water and drain. Store in air-tight container or plastic wrap. Most vegetables should be stored in higher humidity.

#### **Fruits**

Wash and dry. Store in crisper compartment. More aromatic fruits should be stored in plastic bags. Most fruits should be stored in lower humidity.

#### **Prepackaged Meats**

Store in original packaging. After opening, rewrap tightly in plastic wrap or aluminum foil.

#### **Unfrozen Fish, Meats and Poultry**

Remove store wrappings. Then rewrap in plastic wrap, foil or waxed paper, and refrigerate immediately.

#### **Eggs**

Store unwashed in carton or portable egg tray. Use within two weeks.

#### **Milk, Cream, Cottage Cheese**

Keep carton closed. Store on refrigerator shelf and use within five days.

#### **Cheese**

Store in original packaging until ready to use. After opening, rewrap tightly in plastic wrap or aluminum foil.

#### **Left Overs**

Let cool and cover tightly with plastic wrap or foil. Airtight plastic containers work well to prevent drying out and odor transfer.

#### **Freezer Storage**

Foods should be wrapped in material designed for frozen food storage. The wrap must be sealed so as not to allow air or moisture through the wrapping.

**DO NOT refreeze thawed meats.**

#### **Ice Cream**

The firmness of the ice cream will depend on the cream content of the ice cream. The higher quality ice creams usually have a higher cream content requiring colder freezer temperatures to maintain its firmness. Soft ice cream is not always an indication of a temperature problem.

### PRODUCT LOADING SUGGESTIONS

**Items that inhibit proper closing of your doors and affect the temperatures should not extend beyond the front of your shelves or beyond the face of your door shelf assemblies. DO NOT fill freezer with large quantities of unfrozen expecting to "fast freeze" these items. For best results, space out new unfrozen items to allow for air circulation.**

## SERVICE INFORMATION

#### **Before calling service —**

If you think that your refrigerator is not operating properly, check the following before calling your Sub-Zero Factory Authorized Service Agency or dealer. This may save you time and the expense of a service call.

#### **If Refrigerator/Freezer is not operating:**

- Is there electrical power to equipment?
- Is home fuse blown or circuit breaker off?
- Is refrigerator/freezer control on?
- Is condenser clean?
- Has door been left open? Be sure no foods are obstructing proper door closing.
- If still not running, unit may be in defrost; wait 30 minutes to see if unit will restart.

#### **If Refrigerator/Freezer is warmer than usual:**

- Check control for proper setting.
- Has door been left open too long?
- Have you recently added a large quantity of food?
- Is condenser behind grille clean? (See page 6.)

#### **If Refrigerator/Freezer runs too much:**

- Is condenser behind grille clean? (See page 6)
- On hot days and warm room ambients, the motor runs longer.
- Have doors been open for extended times or large amounts of food added?

#### **If Refrigerator/Freezer is frosted up:**

- Have the doors been left open?
- Are doors closing and sealing properly?

#### **If you hear unusual noises:**

- These may be normal operating sounds (See page 5 under "Sounds").

#### **If condensation forms inside the unit:**

- This is normal during high humidity and frequent door openings.
- Are doors closing and sealing properly?

#### **If condensation forms on the outside:**

- It is possible during periods of high humidity that some condensation could appear. This condition will subside when humidity levels drop. If condensation is excessive, contact your Sub-Zero Factory Authorized Service Agency.
- Be sure doors are closed and gaskets are sealing.

#### **If it is too hot around freezer compartment (excluding 249R and 249RP):**

- Clean condenser (see page 6).

#### **If there is odor in the unit and ice:**

- Completely clean product (see page 6).
- Cover foods tightly.

#### **If light bulb needs replacing:**

- Turn off circuit breaker to refrigerator, wear gloves to protect against glass (see page 6).

#### **If you hear occasional buzzing:**

- Is water supply connected to icemaker and turned on?

#### **If Refrigerator/Freezer runs too much:**

- Please have model and serial number available (for location refer to page 2 along with pictures of each unit on pages 3 and 4).
- Call your nearest Sub-Zero Authorized Service Agency. For the name of a local Sub-Zero Authorized Service Agency, contact your dealer or: Sub-Zero Freezer Co., Inc., Service Department, P.O. Box 44130, Madison, WI 53744-4130. Phone (800) 222-7820 or e-mail us at [customerservice@subzero.com](mailto:customerservice@subzero.com).