

USE & CARE GUIDE



Grill Module



## Contents

Wolf Grill Module . . . . .	3
Safety Instructions . . . . .	4
Grill Module Features . . . . .	6
Grill Module Operation . . . . .	8
Wolf Grilling Guide . . . . .	14
Grill Module Care . . . . .	16
Troubleshooting Guide . . . . .	17
Service Information . . . . .	18
Wolf Warranty . . . . .	19

Features and specifications are subject to change at any time without notice. Visit our website, [wolfappliance.com](http://wolfappliance.com) for the most up-to-date information.

**IMPORTANT NOTE:** Throughout this guide, dimensions in parentheses are millimeters unless otherwise specified.

## Important Note

To ensure the safe and efficient use of Wolf equipment, please take note of the following types of highlighted information throughout this guide:

**IMPORTANT NOTE** highlights information that is especially important.

**CAUTION** signals a situation where minor injury or product damage may occur if instructions are not followed.

**WARNING** states a hazard that may cause serious injury or death if precautions are not followed.



## Thank You

Your purchase of a Wolf electric grill module attests to the importance you place upon the quality and performance of your cooking equipment. We understand this importance and have designed and built your grill module with quality materials and workmanship to give you years of dependable service.

We know you are eager to start cooking, but before you do, please take some time to read this use & care guide. Whether you are a beginning cook or an expert chef, it will be to your benefit to familiarize yourself with the safety practices, features, operation and care recommendations of the Wolf electric grill module.

Your Wolf grill module is protected by a warranty that is one of the finest in the industry. Take a moment to read the warranty statement at the end of this guide and refer to it should service become necessary.

If service should become necessary, you will need the model and serial numbers of the grill module. Both numbers are listed on the product rating plate, located on the underside of the module. Refer to the illustration below.

**IMPORTANT NOTE:** Performance may be compromised if the electrical supply is less than 240 volts.

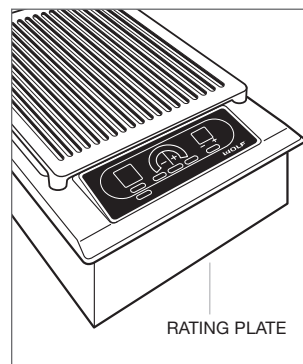

Location of rating plate.

## IMPORTANT INSTRUCTIONS

**IMPORTANT NOTE:** Read all safety instructions before using this appliance.

- Read this use & care guide carefully before using your new grill module to reduce the risk of fire, electric shock or injury to persons.
- Ensure proper installation and servicing. This appliance must be properly installed and grounded by a qualified technician. Have the installer show you the location of the circuit breaker or fuse so that you know where to turn off power.
- Warranty service must be performed by Wolf factory certified service.
- Before performing any service, disconnect the power supply to the module by switching off the circuit breaker or removing the fuse.
- Always properly clean and maintain the module as outlined in care recommendations on page 16.

### **⚠ WARNING**

To eliminate the risk of burns or fire when reaching over heated surface units, cabinet storage space located above the surface units should be avoided. If cabinet storage is to be provided, the risk can be reduced by installing a ventilation hood that projects horizontally a minimum of 5" (127) beyond the bottom cabinets.

## IMPORTANT INSTRUCTIONS

### GENERAL SAFETY REQUIREMENTS

- This appliance is for household use only and must not be put to any other use.
- Use sturdy, properly insulated gloves or pot holders. Dish towels or other substitutes can become entangled, causing burns. Keep pot holders dry. Wet pot holders create steam and cause burns. Keep pot holders away from open flames when lifting or moving utensils.
- Children should not be left alone or unattended in an area where the grill module is being used. Never allow them to sit, stand or play on or around the module at any time. Do not store items of interest to children around or below the module.
- When using the grill module, do not touch the module or immediate surrounding areas. These surfaces become extremely hot and could cause burns. Be certain that all controls are turned off by touching the OFF ON touch pad and that the module has cooled before touching or cleaning any surfaces.
- Never leave the grill module unattended. High flame and fatty meats will promote flare-ups.
- Do not use water on grease fires. Smother fire or flame or use dry chemical or foam-type extinguisher.
- Do not repair or replace any part of the grill module unless specifically recommended in literature included with this appliance. All service is to be referred to Wolf factory certified service.
- Do not line the drip pan or radiator plates or cover the entire grate with aluminum foil. Small foods, such as vegetables, can be wrapped and cooked in aluminum foil packets.
- Do not use the grill module for warming a room.
- Do not store combustible, flammable or explosive materials near the grill module or adjacent cabinets.
- Do not heat unopened glass or metal containers of food on the grill module. Pressure may build up and cause the container to burst, resulting in serious personal harm or damage to the module.
- Clothing fires are potential hazards. Do not wear long flowing sleeves around the grill module. They are easily caught on pan handles or ignited by flare-ups. Highly flammable clothing, especially synthetic fabrics, should not be worn while cooking.
- Flavor enhancers, such as charcoal briquettes or wood chips, are not to be used with the grill module.

## Grill Module Features

- Integrated design allows for installation of multiple cooktops or modules.
- Crafted of heavy-duty stainless steel.
- Two independently controlled 1,400-watt heating elements ensure precise control in front and rear zones for year-round grilling.
- Illuminated touch controls with graduated control lighting.
- Low-profile, porcelain-coated cast iron grilling grate.
- Easy-to-clean, porcelain-coated grease deflection plates and removable collection pan.
- Lock mode.
- Countdown timer with 1 to 99 minute range.
- CSA certified for US and Canada.
- Two and five year residential warranty—exclusions apply, see warranty at the end of this guide.

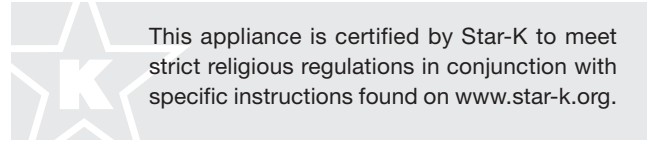

### GRILL MODULE

Model IG15/S

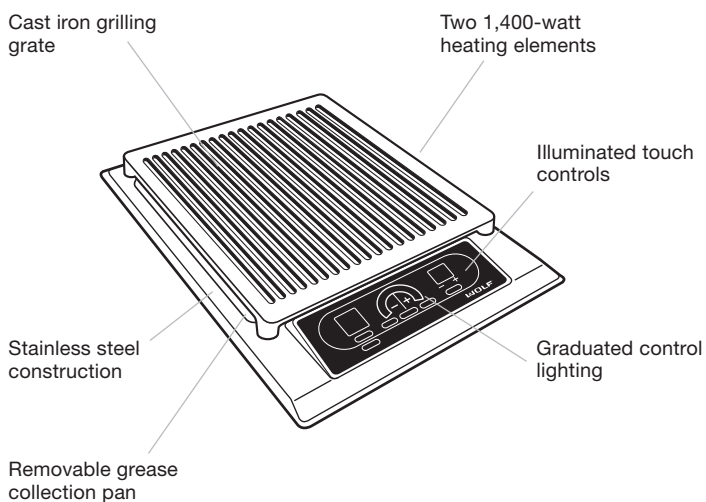

## Grill Module Features

### GRILL MODULE ASSEMBLY

For proper operation, the electric grill module must be assembled in the correct alignment. Refer to the illustration below.

- Insert the grease collection pan into the stainless steel outer grill pan with the hole for the receptacle facing toward the front of the module.
- Insert the two grease deflection plates into the grease collection pan, with the handles running front to back.
- Plug the electric element into the receptacle in the front of the module.
- Position the grilling grate with feet seated into the dimples on the outer grill pan. The slots of the grate run front to back.

### OPTIONAL ACCESSORIES

Optional accessories are available through your authorized Wolf dealer. For local dealer information, visit the find a showroom section of our website, [wolfappliance.com](http://wolfappliance.com).

- Filler strip for installation with another cooktop or module.

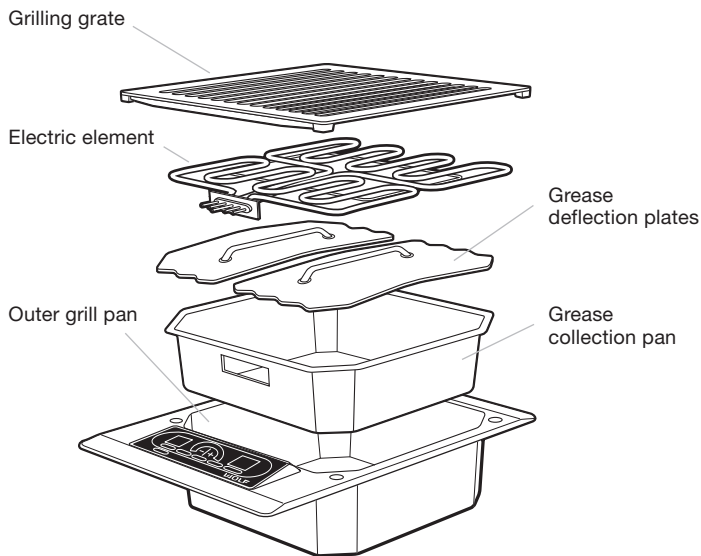

Grill module assembly.

## Modes of Operation

### LOCK MODE

In lock mode, all touch pad operations on the control panel are disabled and the heating elements are deenergized. A steady glowing light within the “key” symbol indicates that the module is locked. Refer to the illustration below.

- To lock the control panel, touch and hold the key symbol for 3 seconds. Three chimes will sound and the light within the key symbol will illuminate. The module is now in lock mode.
- To unlock the control panel, touch and hold the key symbol for 3 seconds. Two chimes will sound and the light within the key symbol will go out. The module is now in idle mode.

**IMPORTANT NOTE:** When the module is powered up for the first time or if there has been a power outage, the module will default to lock mode.

### IDLE MODE

After unlocking the control panel as described in lock mode, the module enters the idle mode of operation. All touch pad operations on the control panel are enabled.

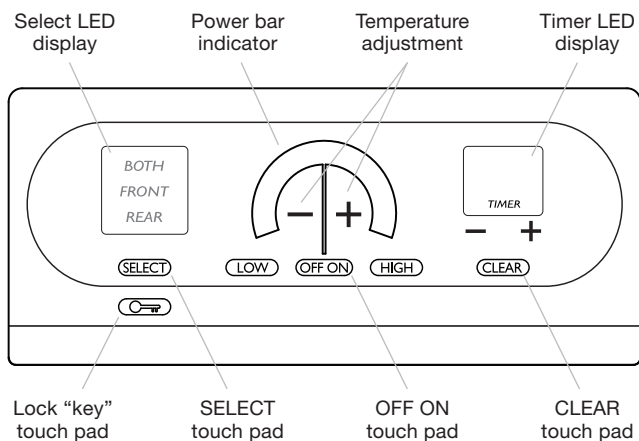

Control panel.

## Grill Module Operation

The Wolf electric grill module operates by automatically cycling the heating elements between zero power and full power. As the heat is increased on the control panel, the element will stay at full power for longer periods and have shorter periods of zero power.

### INITIAL START-UP

Before using for the first time, clean your grill module thoroughly with hot water and a mild detergent. Rinse and dry with a soft cloth. This removes any residual oil and grease left on the surface from the manufacturing process. Refer to care recommendations on page 16. The grill module must be reassembled in the correct alignment as shown on the previous page.

When the grill module is powered up for the first time it will default to lock mode. To unlock the control panel, touch and hold the key symbol for 3 seconds.

Allow a initial burn-in period of approximately 10 minutes before cooking on the grill module.

**IMPORTANT NOTE:** A small amount of smoke and odor may be noticed during the initial break-in period.



## Grill Module Operation

### SETTING CONTROLS

The control panel of your electric grill module is illuminated and features touch controls with graduated control lighting. Refer to the illustration below.

To activate the grill module, first touch the OFF ON touch pad on the control panel. The power bar indicator will begin to blink and show a half-power status. To complete the activation, touch one of the following symbols or touch pads while the power bar indicator is still blinking:

- Touch the + symbol to set the power output at half power and complete the activation.
- Touch the – symbol to set the power output at half power and complete the activation.
- Touch HIGH to set the temperature to full power and complete the activation.
- Touch LOW to set the power output to the lowest power and complete the activation.

To change the power level setting once the module is activated and the power bar indicator remains steadily lit:

- Touch the + symbol to increase the power level on the power bar indicator.
- Touch the – symbol to decrease the power level on the power bar indicator.
- Touch HIGH to increase the power level directly to full power.
- Touch LOW to decrease the power level directly to the lowest power.
- Touch OFF ON to turn the module off.

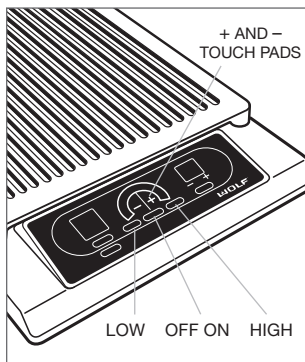

Touch control panel.

## Grill Module Operation

### HEAT SETTING GUIDE

SETTING	USES
LOW to MEDIUM	Holding food to keep warm.
MEDIUM HIGH	Grilling breads, fresh sausage and marinated pork.
HIGH	Searing and grilling meats and grilling vegetables.

### SELECT FEATURE

The select feature allows each of the two 1400-watt elements to be operated at the same power level or independently. With the front element set at a different power level than the rear element, you can grill a variety of foods at the same time.

During normal start-up operation, the BOTH indicator light is illuminated, meaning both the front and rear elements are energized and set at the same power level. Refer to the illustration below for location of the SELECT touch pad and indicator lights.

To turn the elements on individually, touch the SELECT touch pad to select either the front or rear element.

- When the FRONT indicator light is illuminated, touch the OFF ON touch pad and any power level setting for the front element.
- When the REAR indicator light is illuminated, touch the OFF ON touch pad and any power level setting for the rear element.

If after five seconds no power level is entered, the module will return to the idle mode.

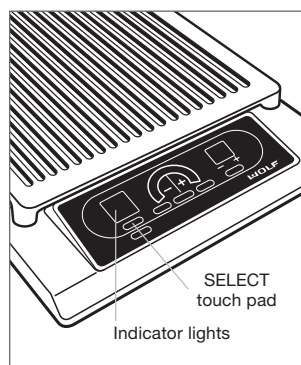

Select touch pad.

## Grill Module Operation

### SELECT FEATURE

To change the power level setting of the elements individually, touch the SELECT touch pad to select either the front or rear element.

- When the FRONT indicator light is illuminated, adjustments can be made to the power level of the front element using the HIGH and LOW touch pads or the + and – symbols.
- When the REAR indicator light is illuminated, adjustments can be made to the power level of the rear element using the HIGH and LOW touch pads or the + and – symbols.

Once individual power levels are set, the FRONT and REAR indicator lights will illuminate alternately. To change an individual setting, either wait until the desired indicator light is illuminated or touch the SELECT touch pad to select either the front or rear element.

To change individual power level settings to the same setting, touch the SELECT touch pad until the BOTH indicator light is illuminated.

- Enter any power level setting within 5 seconds and both elements will be set to that power level.
- If only one element is energized and no other setting is entered, both elements will be set to the power level of that element.
- If after 5 seconds no power level is entered, both elements will be set to the lower of the two power level settings.

To turn an element off individually, touch the SELECT touch pad to select the element, then touch OFF ON within 5 seconds. If the OFF ON touch pad is touched after 5 seconds, the entire module will turn off.

To turn both elements off, touch the SELECT touch pad until the BOTH indicator light is illuminated, then touch the OFF ON touch pad within 5 seconds to turn off both elements.

## Grill Module Operation

### TIMER

The grill module features a countdown timer located in the control panel. Refer to the illustration.

The timer may be set in one-minute increments up to 99 minutes. Once set, the remaining time will be illuminated in the control panel as it counts down. The timer can be used anytime the module is not in lock mode.

- To start the timer, touch + on the timer control. Touch and hold + or – until the desired time is shown in the timer display. The timer will begin its countdown in minutes, 3 seconds after the time is set.
- A warning chime will sound when the timer has one minute left and begins to countdown in seconds.
- When the timer reaches 0, an audible chime will sound. The chime will continue to sound every 30 seconds until CLEAR is touched.

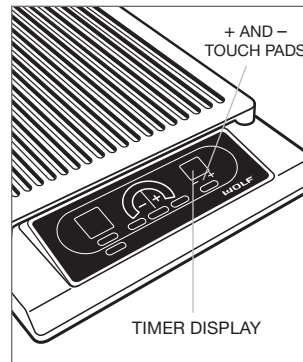

Timer controls.

## Using the Grill Module

### GRILLING

**IMPORTANT NOTE:** Before operating, make sure the grill module is assembled correctly. Refer to grill module assembly on page 7.

- 1) Touch OFF ON to turn the unit on.
- 2) Touch HIGH and preheat the grill module for 10 minutes. Always preheat the grill module.
- 3) Once preheat is finished, set the desired power level setting of each element, together or independently. Refer to select feature on page 10 to set the element power levels individually.
- 4) Add food for grilling. Refer to the grilling guide on pages 14–15 to estimate grilling times.
- 5) Remove food from the grill.
- 6) Touch OFF ON to turn the unit off.

### GRILLING TIPS

- Never leave food unattended while grilling.
- Trim excess fat from meats and notch the remaining fat at 2" (51) intervals to avoid flare-ups and curling.
- To burn grease drippings off the grilling grate after grilling, operate the grill at HIGH for five minutes. To clean, refer to care recommendations on page 16.
- To help retain juices, allow meat to defrost in the refrigerator overnight instead of microwaving.
- Apply salt only after grilling to prevent meat from drying out.
- To prevent juices from escaping, use a spatula or tongs to turn meat instead of piercing with a fork.
- Baste meat with barbecue sauce or other sugar-based sauces only during the last few minutes of grilling to prevent burning.
- Brush vegetables and lean cuts of meat, skinless poultry, fish and seafood with oil to prevent sticking.
- Turn food only once, halfway through grilling time.
- Soak bamboo skewers in cold water for 30 minutes before using them.

## Grilling Guide

FOOD	THICK/WEIGHT	SETTING	INTERNAL TEMP	TIME	COMMENTS
<b>BEEF</b>					
Hamburgers	1/2" (25) to 3/4" (19)	HIGH	160°F (70°C) Medium	16–20 min	Grill, turning once when juices rise to the surface.
Steaks, rare	1" (25) thick	HIGH	140°F (60°C)	11–13 min	Remove excess fat from edges. Notch remaining fat on outer edges to prevent curling.
Steaks, medium	1" (25) thick	HIGH	160°F (70°C)	16–18 min	
Steaks, well done	1" (25) thick	HIGH	180°F (80°C)	21–23 min	
<b>PORK</b>					
Chops	3/4" (19) thick	HIGH	160°F (70°C)	14–17 min	Remove excess fat from edges. Notch remaining fat on outer edges to prevent curling.
Tenderloin, whole	1 lb (.6 kg) to 1 1/2 lbs (.7 kg)	HIGH	160°F (70°C)	50–60 min	Brush with oil and seasoning.
Tenderloin, marinated	1 1/2 lbs (.7 kg)	MED HIGH	160°F (70°C)	50–60 min	
Sausages or brats, fresh		MED HIGH	180°F (80°C)	20–25 min	Do not pierce with a fork.
Hot dogs	8 per 1 lb (.6 kg)	HIGH	140°F (60°C)	5–7 min	Place vertically on grate.
<b>POULTRY</b>					
Chicken breasts, bone-in		HIGH	170°F (75°C)	35–40 min	Begin with skin side up. Pound with a meat tenderizer until even thickness.
Legs and thighs, bone-in		HIGH	180°F (80°C)	30–40 min	
Chicken breasts, boneless	1/2" (13) thick	HIGH	170°F (75°C)	13–15 min	
Cornish hens, halved	1 1/2 lbs (.7 kg) to 2 lbs (.9 kg)	HIGH	180°F (80°C)	30–35 min	
<b>SEAFOOD</b>					
Fish fillets or steaks	1" (25) thick	HIGH		16–20 min	Brush with oil to prevent sticking.
Shrimp	26–30 per 1 lb (.6 kg)	HIGH		18–20 min	Turn frequently.

Grilling Guide

FOOD	THICK/WEIGHT	SETTING	INTERNAL TEMP	TIME	COMMENTS
<b>VEGETABLES</b>					
Bell peppers, whole		HIGH		15–18 min	Turn every 4 minutes.
Bell peppers, quartered		HIGH		10–12 min	Turn every 3 minutes.
Corn on cob, husked		HIGH		25–30 min	Soak in water for 30 minutes before grilling.
Corn on cob, unhusked		HIGH		40 min	
Portobello mushrooms		HIGH		10–12 min	Brush lightly with oil.
Kabobs, beef	2" (51) cubes	HIGH	160°F (70°C)	30–35 min	When grilling, make sure meat reaches minimum internal temperature.
Kabobs, chicken	2" (51) cubes	HIGH	170°F (75°C)	30–35 min	
<b>BREADS</b>					
Buns, hamburger or hot dog		MEDIUM HIGH		3–4 min	Watch carefully.
Texas toast		MEDIUM HIGH		7 min	Brush with butter before grilling.

## Care Recommendations

**IMPORTANT NOTE:** Make sure the grill module is off and all surfaces are cool before cleaning any part of the unit.

### STAINLESS STEEL SURFACES

**IMPORTANT NOTE:** Do not use abrasive cleaners; they will permanently scratch stainless steel surfaces. Salt and some cooking liquids may pit and stain the surface. Remove these spatters immediately.

Use a spray degreaser to remove fingerprints and greasy spatters. Spray on a cloth and wipe the surface. Buff dry immediately to avoid streaking. For hard water stains, use white vinegar and water.

For general cleaning, use a soft, nonabrasive stainless steel cleaner like Signature polish and apply with a soft lint-free cloth. To bring out the natural luster, lightly wipe the surface with a water-dampened microfiber cloth followed by a dry polishing chamois. All work should follow the grain direction of the finish. Better results are obtained by keeping the cloth in continuous contact with the stainless steel.

Signature polish is available from Signature Limited Laboratory, P. O. Box 13436, Dayton, Ohio 45413, or call 877-376-5474.

### GENERAL CLEANING

#### Control panel.

- Use a spray degreaser to remove fingerprints and greasy spatters. Spray on a cloth and wipe the surface. Do not spray directly on the control panel.
- Use a clean cloth or sponge and wipe the control panel with warm water and a mild detergent. Rinse and dry immediately.

#### Grilling grate.

- Before cleaning, remove all excess grease and burned-on food particles. Clean with a nonabrasive cleaner such as liquid detergent and hot water, or a paste of baking soda and water. Do not immerse in water. Spray degreasers and mild abrasive cleaners may be used.

#### Electric element.

- Do not immerse in water. If food particles are burned-on, wipe clean by hand using a damp cloth.

#### Grease deflection plates and collection pan.

- Before cleaning, remove all excess grease and burned-on food particles. Wash in hot water with a mild detergent. Rinse and dry.



### Troubleshooting

If your Wolf grill module is not operating properly, use the following troubleshooting guide before calling Wolf factory certified service. This guide will save you time and trouble and may help you avoid the expense of a service call.

#### **Grill module does not operate.**

- Module is in lock mode. Touch and hold the key symbol for 3 seconds to unlock the control panel.
- Check the household fuse or circuit breaker to see if it has been blown or tripped. A power outage may also have caused a disruption in service.
- Verify that the electrical connection to the module has not been disconnected.

## Service Information

When requesting information, literature, replacement parts or service, always refer to the model and serial numbers of your grill module. Both numbers are listed on the product rating plate, located on the underside of the module. Refer to the illustration on page 3. Record the rating plate information below for future reference.

Model Number: \_\_\_\_\_

Serial Number: \_\_\_\_\_

Installation Date: \_\_\_\_\_

Wolf Factory Certified Service:

\_\_\_\_\_

Phone: \_\_\_\_\_

Authorized Wolf Dealer:

\_\_\_\_\_

Phone: \_\_\_\_\_

### BEFORE CALLING FOR SERVICE

Before calling Wolf factory certified service, refer to the troubleshooting guide on page 17.

### PRODUCT REGISTRATION

Register your new Wolf product today so that we may ensure your satisfaction. You may register by one of the following options:

- 1) Mail in the completed Wolf product registration card.
- 2) Register online at [wolfappliance.com](http://wolfappliance.com).
- 3) Register by phone by calling Wolf customer care at **800-222-7820**.

The model and serial numbers of your unit are printed on the enclosed Wolf product registration card. If you provide us with your e-mail address, we will send you exciting new product updates and recipes as they become available, along with information on special events.

The information and images in this guide are the copyright property of Wolf Appliance, Inc. Neither this guide nor any information or images contained herein may be copied or used in whole or in part without the express written permission of Wolf Appliance, Inc. ©Wolf Appliance, Inc. all rights reserved.

Wolf, Wolf & Design, Wolf Gourmet, W & Design and the color red as applied to knobs are registered trademarks and service marks of Wolf Appliance, Inc. Sub-Zero, Sub-Zero & Design, Dual Refrigeration, Constant Care and The Living Kitchen are registered trademarks and service marks of Sub-Zero, Inc. (collectively, the "Company Marks.") All other trademarks or registered trademarks are property of their respective owners in the United States and other countries.

# Wolf Appliance Products Limited Warranty

FOR RESIDENTIAL USE ONLY

## FULL TWO YEAR WARRANTY\*

For two years from the date of original installation, your Wolf Appliance product warranty covers all parts and labor to repair or replace, under normal residential use, any part of the product that proves to be defective in materials or workmanship. All service provided by Wolf Appliance under the above warranty must be performed by Wolf factory certified service, unless otherwise specified by Wolf Appliance, Inc. Service will be provided during normal business hours.

## LIMITED FIVE YEAR WARRANTY

For five years from the date of original installation, Wolf Appliance will repair or replace the following parts that prove to be defective in materials or workmanship: gas burners (excluding appearance), electric heating elements, blower motors (ventilation hoods), electronic control boards, magnetron tubes and induction generators. The part(s) will be repaired or replaced, free of charge, with the owner paying for all other costs including labor. All service provided by Wolf Appliance under the above warranty must be performed by Wolf factory certified service, unless otherwise specified by Wolf Appliance, Inc. Service will be provided during normal business hours.

## TERMS APPLICABLE TO EACH WARRANTY

The warranty applies only to products installed for normal residential use. The warranty applies only to products installed in any one of the fifty states of the United States, the District of Columbia or the ten provinces of Canada. This warranty does not cover any parts or labor to correct any defect caused by negligence, accident or improper use, maintenance, installation, service or repair.

**THE REMEDIES DESCRIBED ABOVE FOR EACH WARRANTY ARE THE ONLY ONES THAT WOLF APPLIANCE, INC. WILL PROVIDE, EITHER UNDER THIS WARRANTY OR UNDER ANY WARRANTY ARISING BY OPERATION OF LAW. WOLF APPLIANCE, INC. WILL NOT BE RESPONSIBLE FOR ANY CONSEQUENTIAL OR INCIDENTAL DAMAGES ARISING FROM THE BREACH OF THIS WARRANTY OR ANY OTHER WARRANTY, WHETHER EXPRESS, IMPLIED OR STATUTORY.**

Some states do not allow the exclusion or limitation of incidental or consequential damages, so the above limitation or exclusion may not apply to you. This warranty gives you specific legal rights and you may also have other legal rights that vary from state to state.

To receive parts and/or service and the name of Wolf factory certified service nearest you, contact Wolf Appliance, Inc., P.O. Box 44848, Madison, WI 53744; check the contact & support section of our website, [wolfappliance.com](http://wolfappliance.com) or call 800-222-7820.

\*Stainless steel doors, panels, handles, product frames and interior surfaces are covered by a limited 60-day parts and labor warranty for cosmetic defects.

\*Replacement filters for ventilation hood recirculating kits are not covered by the product warranty.





WOLF APPLIANCE, INC. P. O. BOX 44848 MADISON, WI 53744 WOLFAPPLIANCE.COM 800.222.7820

817488 REV-A

3/2011

